

SCL800 Stairclimber Service & Installation Bulletin

Assembly

The SCL 800 ships boxed and requires assembly. Two technicians are recommended. Assembly hardware is SAE and installation requires the following tools:

- 5/32" hex wrench
- 7/32" hex wrench or socket
- 1/2" wrench

Assembly guides ship with the unit. Care should be taken when unboxing to gather all parts and pieces prior to disposing of any packaging. Assembly guides can be found on each unit's product page at Precor.com.

Once assembled, run the unit fully to check all functions prior to putting into service

Console

The SCL 800 will only work with the P31 console.

Note: Some SCL 800 units were built with Version 1 of the P31 SCL 800 software (305239-101 009). There is now a Version 2 that has minor updates, bug fixes and has an updated build number from 009 to 012 (305239-101 012). If Version 1 software is found, use the CSAFE flashing procedure to update the console to Version 2.

To check the console software version on the console, access the information menu and navigate to MAIN CONSOLE SW to view the current console software version. If the build number is 009, flash the console using the 305239-101_bld012.a90 software file. P31 software can be found on the [Precor Connect software page](#) in the General Release section under "Commercial UPCA SW (LED)."



Preventative Maintenance





Refer to the [Cardio Maintenance Guide](#) for SCL 800 preventative maintenance. All basic maintenance and cleaning guidelines are applicable as well as the following items specific to the SCL 800:

- Monthly
 1. Note step count
 2. Test Remote Motion Controls (RMC)
 3. Clean and test obstruction sensor
- Quarterly
 1. Inspect steps, step shafts, and bearings
 2. Inspect primary drive chain tension
- Annually
 1. Inspect sprockets
 2. Inspect step chain and chain master link. Adjust chain tension as needed.
 3. Clean step chain with soft brush and vacuum

Active Status Light

The Active Status Light works similarly to the ASL on the EFX 800. The brightness can be adjusted and the ASL can be set to off if that is desired. Located on the right lower corner of the unit, the ASL has the same color status pattern as on other ASL equipped units. There are four supported states:

1. **Solid blue** - indicates normal operation
2. **Pulsing blue** - indicates preventative maintenance is required
3. **Solid yellow** - indicates an error has occurred but the machine is useable
4. **Pulsing yellow** - indicates a loss of major function was detected.

				
Off	Solid Blue	Pulsing Blue	Solid Yellow	Pulsing Yellow
<ul style="list-style-type: none"> > Power is OFF > Possible hard failure > ASL brightness OFF 	<ul style="list-style-type: none"> > All OK 	<ul style="list-style-type: none"> > Maintenance due 	<ul style="list-style-type: none"> > Recovered fault condition 	<ul style="list-style-type: none"> > Non-recoverable fault

The Maintenance Counter will cause the ASL to flash blue after 1,100,000 steps. The current maintenance step count can be found in the information maintenance menus under **MAINTENANCE COUNTER**.

The counter starts at 1,100,000 steps and counts down. Press and hold the Start button to reset. More information on the ASL's functions and settings can be found in the [Active Status Light](#) section of the service manual.

Covers

For access to most areas that will require maintenance and service, the covers can be removed without tools (a small nylon tipped screwdriver or other slim non-metallic tool may be needed to remove the gasket cover). Refer to the maintenance manual for all [cover removal/replacement](#) procedures.

1) Gasket Cover	2) Top Cover
-----------------	--------------

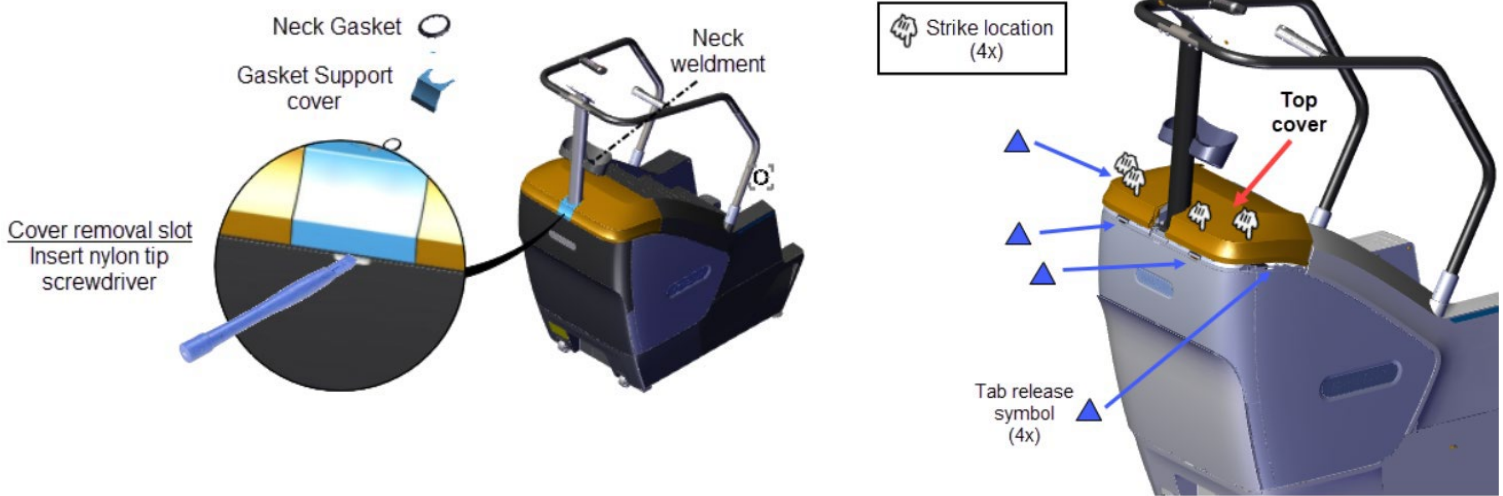

3) Forward Cover	4) Side covers
------------------	----------------

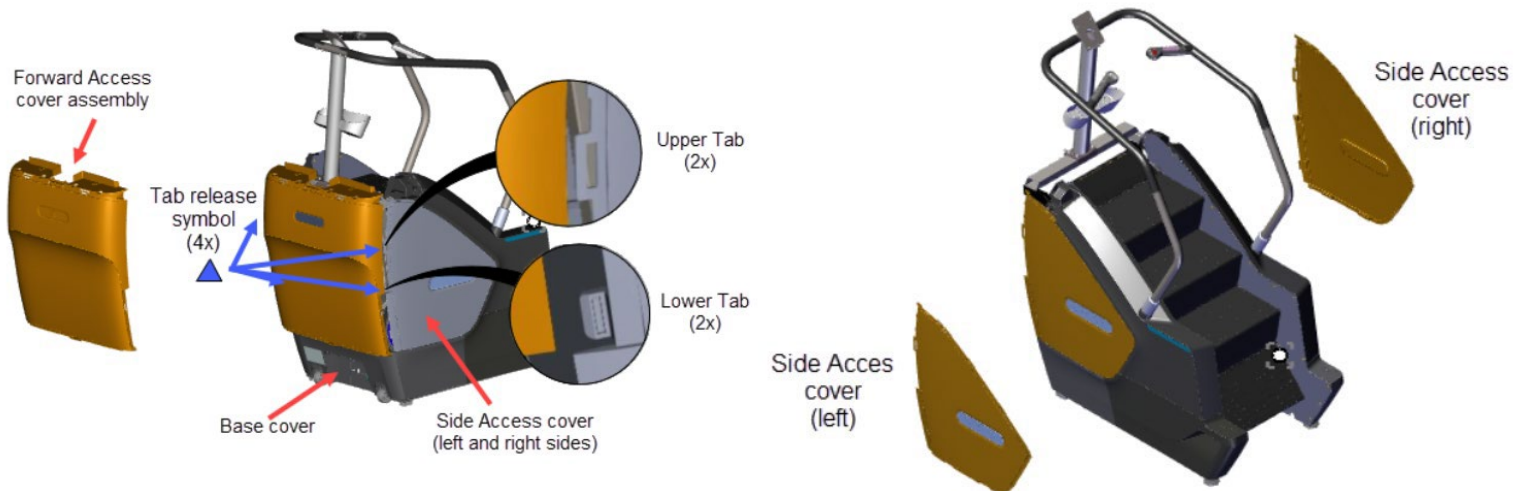

Speed Sensor

Both step speed and step count are monitored by the speed sensor system. The SCL 800's speed sensor system works with a cogged sprocket that passes in front of two LEDs on the speed sensor board.

If the signals from the LEDs disagree by more than 20 steps per minute, or is missing for more than 410 ms, the unit will generate an error.

Errors [13](#) and [70](#) are related to issues with the SCL800 speed sensor.

Care should be taken when working in this area as misalignment of the sprocket could be one cause for speed sensor errors.

See the service manual for the [speed sensor PCA board replacement](#) and for [sprocket replacement](#).

Drive Chain

Both the drive and step chain are made from motorcycle 428 O-ring chain and should require no maintenance outside periodic cleaning.

The drive chain connects the speed sensor drive sprocket to the step drive sprocket.

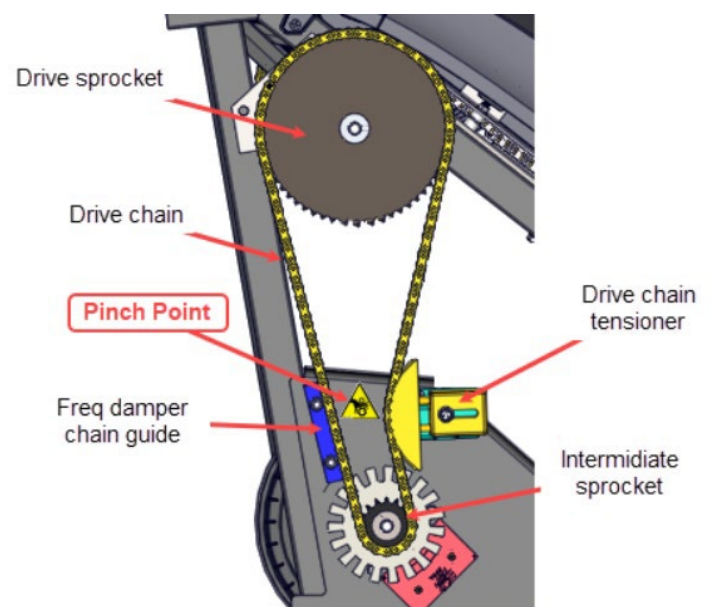

To remove the drive chain, the drive chain tensioner will be loosened which will allow the chain to be removed.

Two distances will be measured to ensure proper tensioning. The gap between the tensioner and tensioner guide will be 3/8" and the pinch point distance of the chain between the tensionor and the damper chain guide should be greater than 1" (2.5mm).

See the service manual for [drive chain replacement](#) and [drive chain tensioning](#).

Step Chain

There are two step chains, one on each side of the steps.

Tensioning is done at the tensioning pillow blocks by the top drive sprocket.

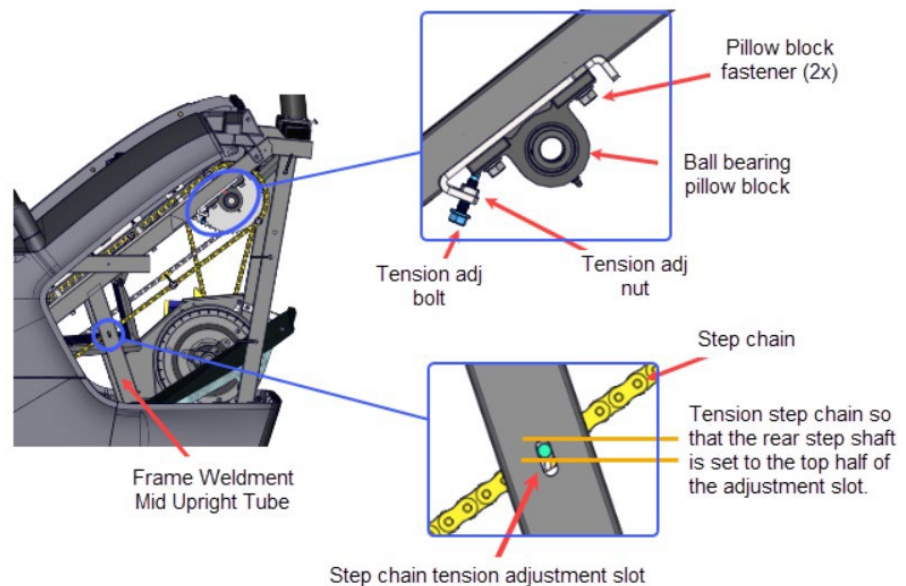

To check the step chain

tension, use the tension adjustment slot on the noted weldment. Tension should be adjusted so that when looking through the adjustment slot, the end of the step shaft is visible in the top half of the adjustment slot. Tensioning is adjusted on both step chains.

See the service manual for [step chain adjustment](#) and for [stair step replacement](#).

Drive Belt

The drive belt connects the Brake Assembly pulley to the Drive Assembly pulley. The drive belt must be replaced at 39 million steps.

The SCL 800 drive belt has an end-of-service life span

of 39 million steps. The SCL 800 maintains a step count independent from the overall machine step count. When the step count reaches 35 to 39 million steps, Warning 78 is recorded in the error log and displays a message alert stating that the drive belt needs to be replaced soon. Normal workout operation is still available during the warning period.

When the step count reaches 39 million steps, Error 79 is recorded in the error log and a drive belt replacement required message is shown. If Error 79 occurs during a workout, the exerciser will be able to continue the workout until ended. The machine operation will then be disabled and "out-of-service" until the drive belt is replaced. See the [Error Code Guide, Errors 78-79](#) for information on these errors.

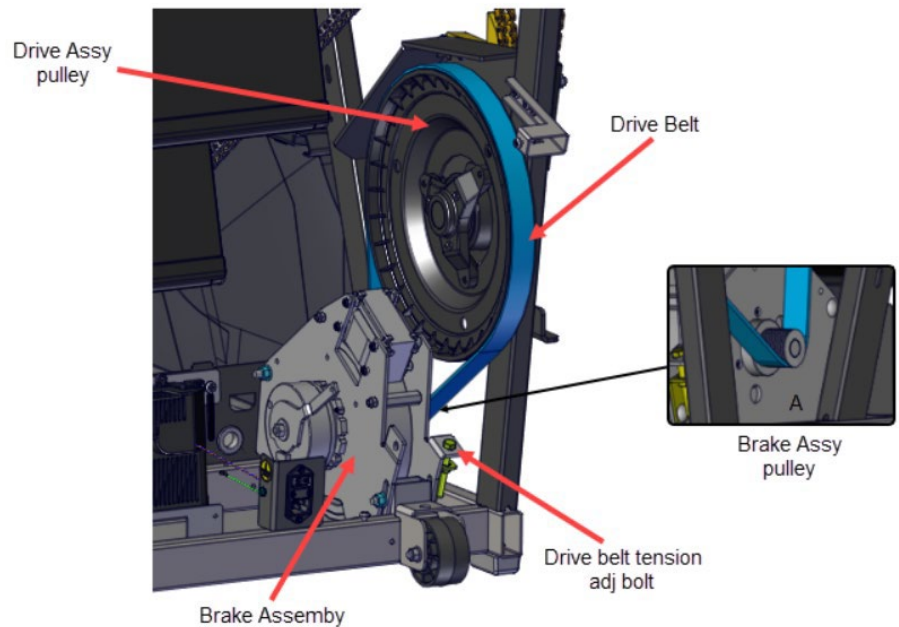

The current drive belt step count can be found in the **INFORMATION DISPLAY > BELT USAGE** parameter, see [LED Console Standard Service Menus](#).

To replace the belt, tension will be removed at the tension adjustment bolt on the brake assembly. Once loosened, the belt can then be removed from the pulleys and slid between the brake assembly and drive belt pulley and taken off the unit.

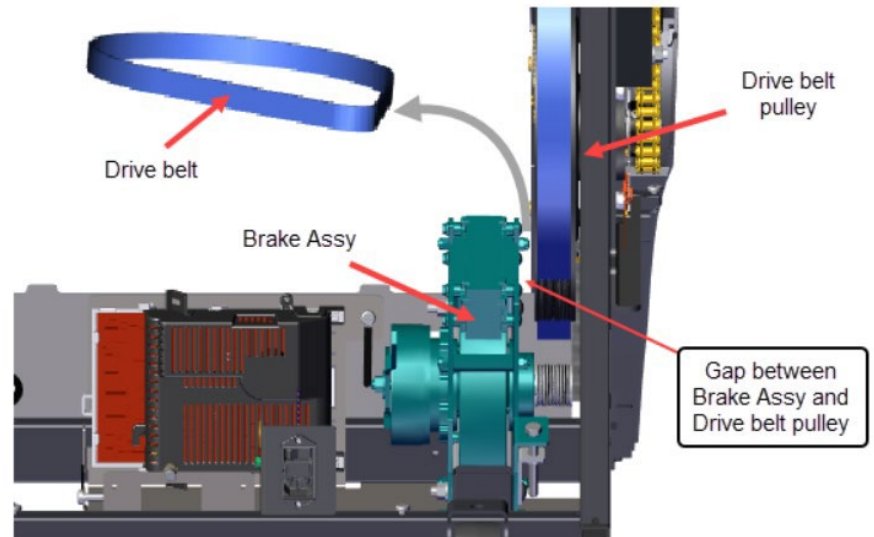

Note: due to slipping concerns, no lubricants should ever be used on the SCL 800 drive belt.

See the SCL800 service manual for [belt removal and replacement](#).

Braking system

The SCL 800 brake assembly is connected to the drive belt. When unpowered or not in use, the SCL 800 braking system holds the steps in place. Should the drive belt fail, the steps will freely move, so belt care and maintenance are important.

During maintenance, should the technician need to move the steps, the holding brake handle can be pushed fully back to release the brake and allow the steps to move freely. The console will flash an error if the holding brake handle is left in the OFF position.

Note: Care needs to be taken when the steps are loose. Keep hands and fingers away from the step chain, drive chain, and all other moving parts. Unless necessary for service, it is recommended to always leave the brake set to ON.

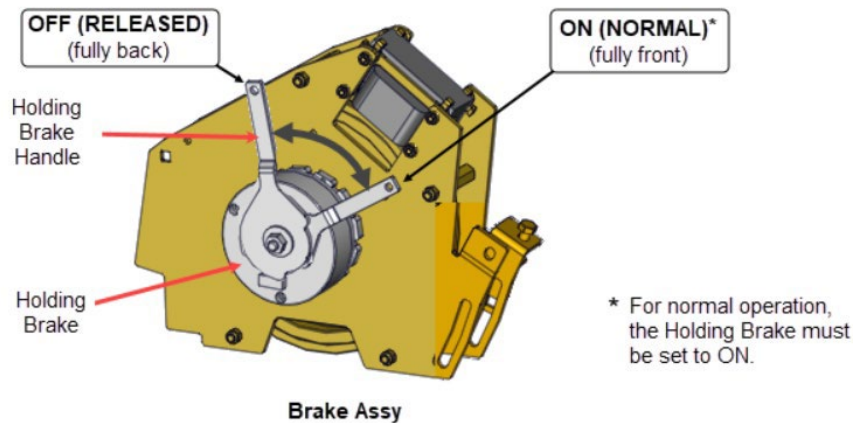

Obstruction Sensor

At the base of the SCL 800 and under the steps are the unit obstruction sensors. The sensors use an IR beam to detect if an obstacle is under the unit. The obstruction sensors will stop step movement and the console will display an “OBSTRUCTION DETECTED” message when an object comes between the sensors. If this occurs during a workout, the workout will only be paused. Once the obstruction is cleared, the user will be able to resume their workout.

The sensors are mounted by brackets to the unit frame and are connected to the LPCA. The sensor on the left is the emitter and the sensor on the right is the receiver. See the SCL 800 service manual for [obstruction sensor replacement](#).

